

# Technical Data

Pump Name

3D 32-160/2.2

Customer	Date	2026-05-21	Company
Contact	Item no.		Issued by
Phone	Project		Phone
E-mail	Project ID		E-mail

## Requested data

1	Pump type	CENTRIFUGAL PUMPS	Fluid	Water	
2	Number of pumps / Reserve	1 / 0	Liquid temperature	°C	20
3	Flow	m³/h	Kin. viscosity	mm²/s	1.005
4	Head	m	Vapour pressure	kPa	2.34
5	Geodetic head	m	PH value		
6	Inlet pressure (pin)	kPa	Density	kg/m³	998.3
7	Available system NPSH		Solids	Weight %	0
8	Ambient temperature	°C	20		

## Pump

9	Pump Name	3D 32-160/2.2	Frequency	Hz	50		
10	Design	CENTRIFUGAL PUMPS	Installation type		STANDARD		
11	Manufacturer	EBARA	Impeller Diameter	Max	mm	166	
12	Speed	1/min		2900	Designed	mm	166
13	No. of Stage	1		Min.	mm	166	
14	Connection	Suction side	EN 1092-2	Flow	Operating	m³/h	
15	Connection	Discharge side	EN 1092-2		Max-	m³/h	20
16	Max Working Pressure	kPa	1000		Min-	m³/h	6
17	Shut-off head	kPa	359.40	Head	Operating	m	
18	Total weight	kg	See the table of "Dimensions".		- (Qmax)	m	25.5
19	Shaft power	kW			- (Qmin.)	m	35.4
20				Max. Shaft Power at max. impeller	kW	2.25	
21	Required pump NPSH	m		Efficiency	%		

## Materials

22	Impeller	AISI 304		
23	Casing	Cast iron		
24	Shaft	AISI 304 (wet extension)		
25				
26				
27				

## Motor

28	Manufacturer	EPE Standard	Insulation class	F		
29	Type	TEFC_3D 32-160/2.2_400_Three Phase	Phases	3~		
30	Specific design	IE3 / 50 Hz / Pole pairs 1	Frame size			
31	Rated power	kW	2.2	Weight	kg	
32	Number of poles	2	Electric voltage	V	400	
33	Speed	1/min	2900	Electric current	A	4.7
34	Degree of protection	IP 55				
35						

## Remarks

# Performance Curve

Pump Name

3D 32-160/2.2

Customer	Date	2026-05-21	Company
Contact	Item no.		Issued by
Phone	Project		Phone
E-mail	Project ID		E-mail

## Requested data

1	Flow	m³/h	
2	Head	m	
3	Geodetic head	m	

## Pump

Operating flow	m³/h		Frequency	Hz	50
Operating head	m		Number of poles		2
Impeller diameter designed	mm	166	Speed	1/min	2900

Test standard: ISO 9906:2012 - Grade3B

Water; 20°C; 998.3kg/m³; 1mm²/s

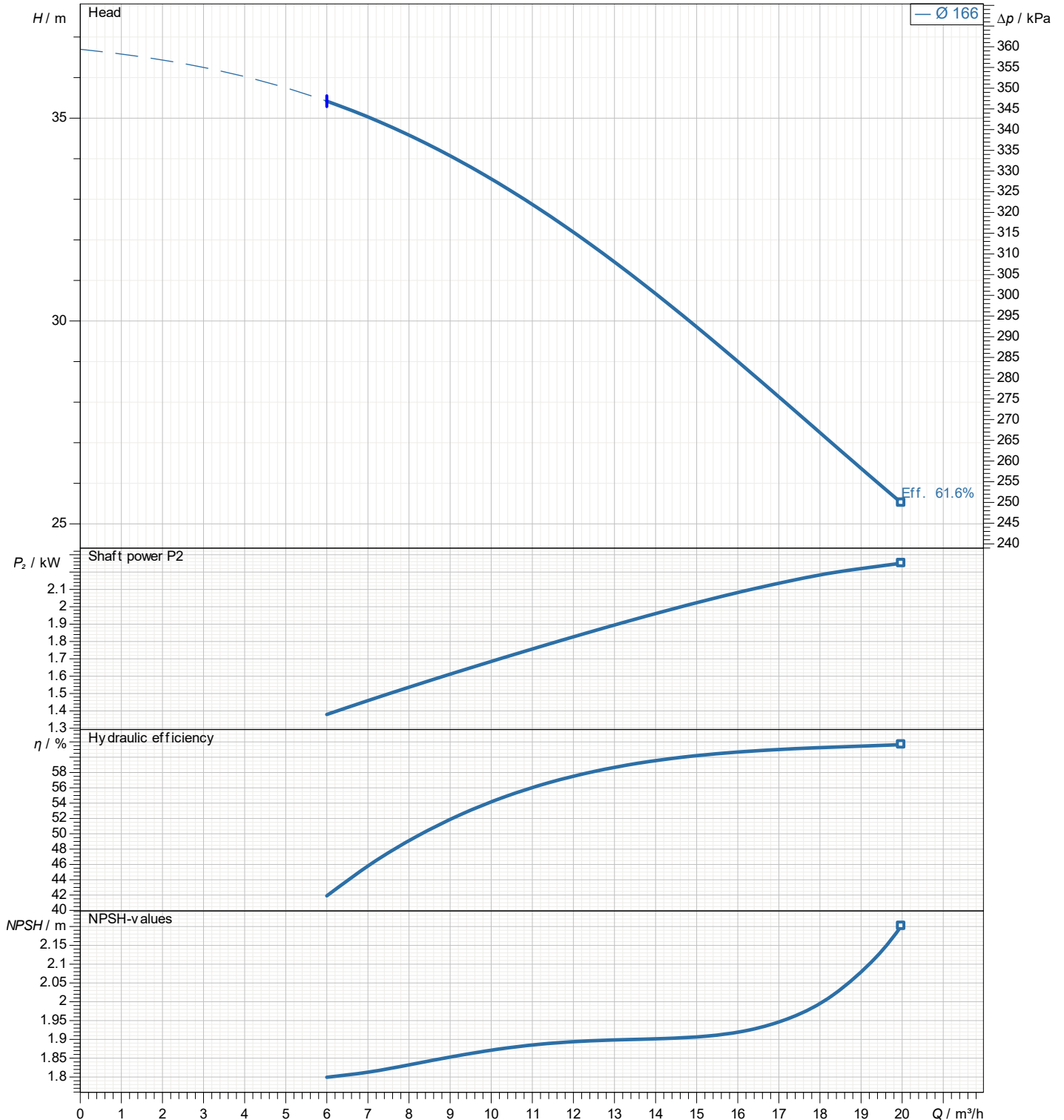

# Dimensions

Pump Name 3D 32-160/2.2

Customer	Date 2026-05-21	Company
Contact	Item no.	Issued by
Phone	Project	Phone
E-mail	Project ID	E-mail

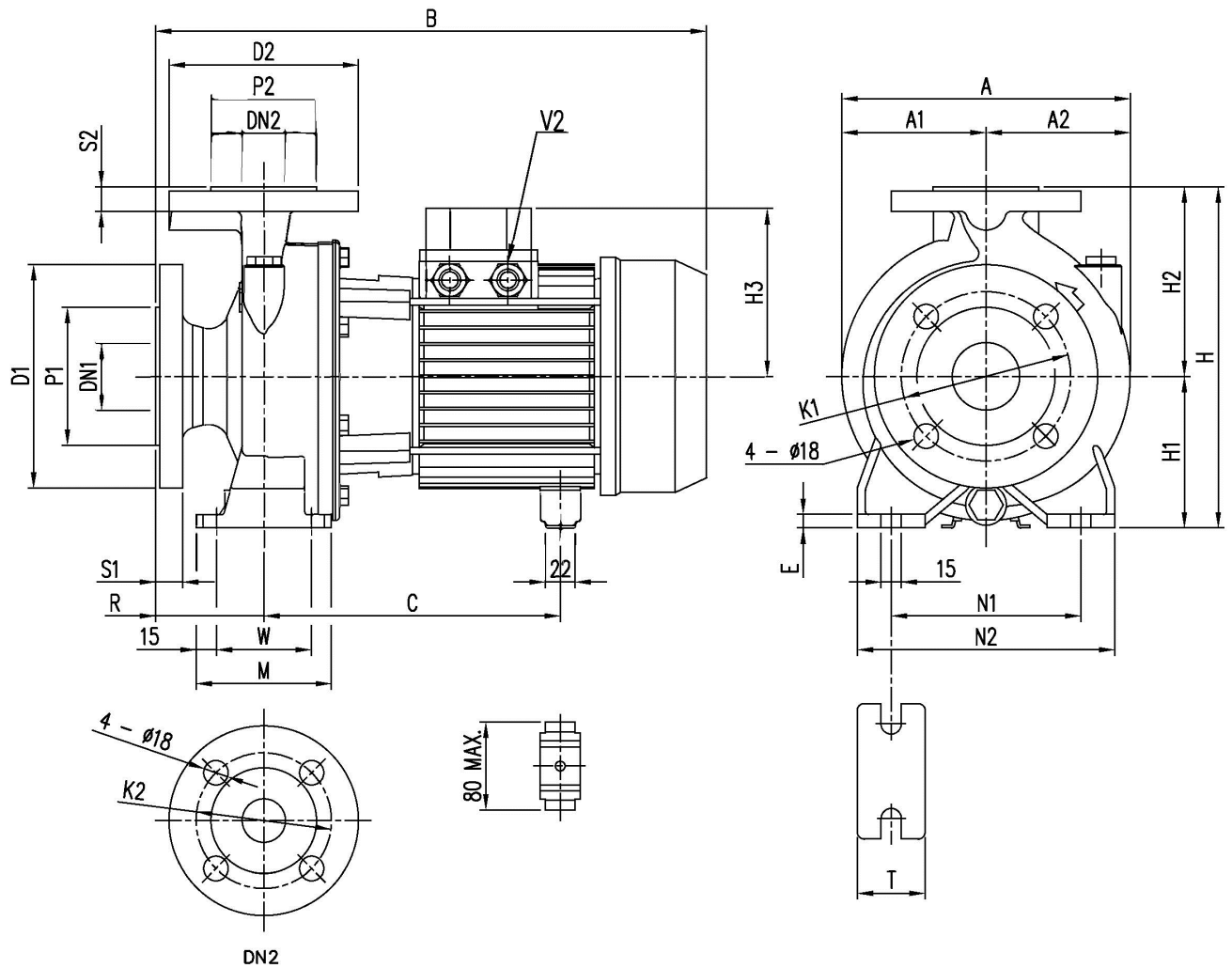

Dimensions in		mm		
1	A	254	H1	132
2	A1	127	H2	160
3	A2	127	H3	119
4	B	431	M	100
5	C	232	N1	190
6	Dia D1	165	N2	240
7	Dia D2	140	R	80
8	Dia DN1	50	S1	20
9	Dia DN2	32	S2	18
10	Dia K1	125	T	50
11	Dia K2	100	V2	M20X1,5
12	Dia P1	102	W	70
13	Dia P2	78	Weight P&M	36 kg
14	E	10		
15	H	292		

(1/3)

# Construction

Pump Name 3D 32-160/2.2

Customer	Date 2026-05-21	Company
Contact	Item no.	Issued by
Phone	Project	Phone
E-mail	Project ID	E-mail

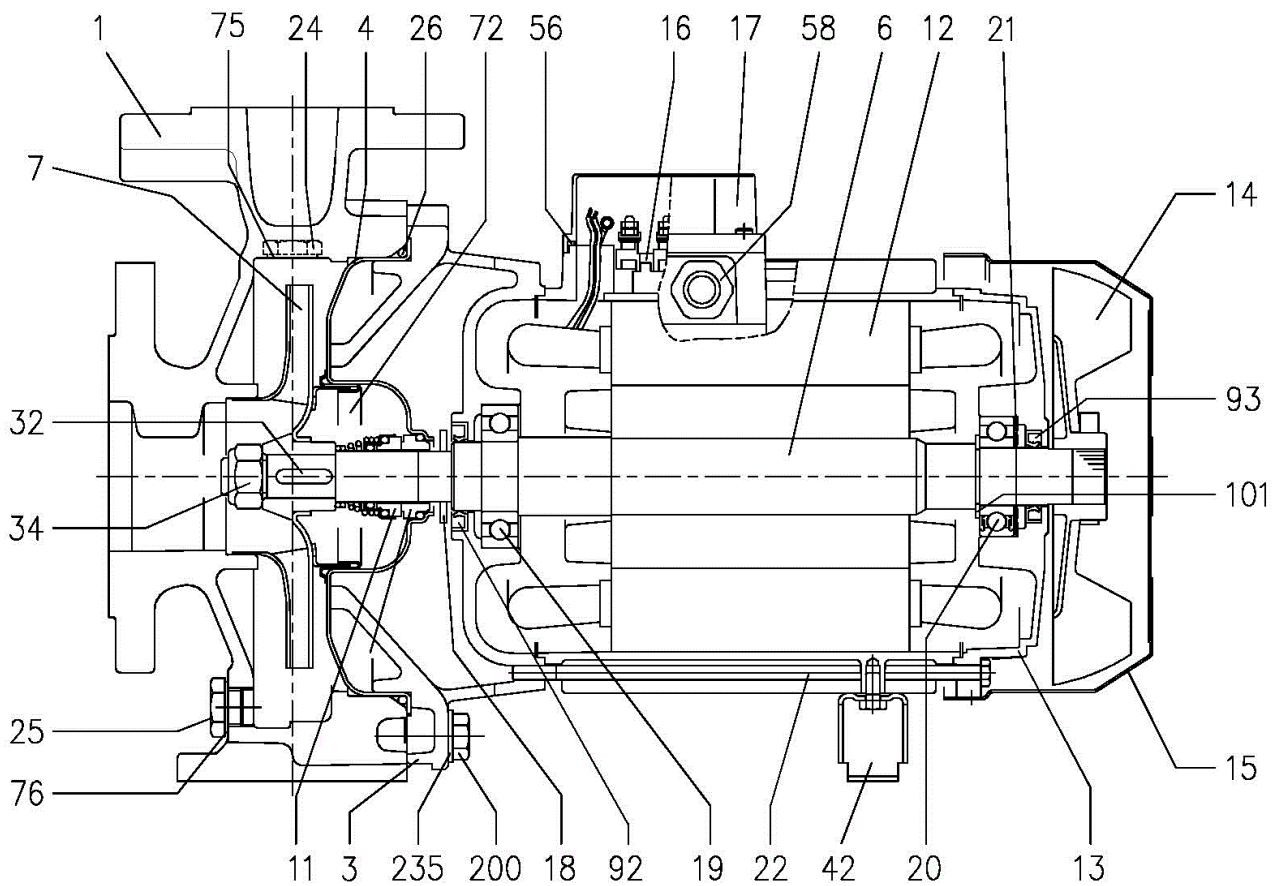

(2/3)

# Construction

Pump Name 3D 32-160/2.2

Customer	Date 2026-05-21	Company
Contact	Item no.	Issued by
Phone	Project	Phone
E-mail	Project ID	E-mail

N°	PART NAME	MATERIAL	DIMENSIONS	STANDARD	Q.TY
1	Casing	Cast iron EN-GJL-250-EN 1561			1
3	Motor bracket [1]	-			1
4	Casing cover	EN 1.4301 (AISI 304)			1
6	Shaft with rotor - Wet extension	EN 1.4301 (AISI 304)			1
7	Impeller [2]	-			1
11	Mechanical seal [3]	-			1
12	Motor frame with stator	-			1
13	Motor cover	Aluminium			1
14	Fan	PA			1
15	Fan cover	Fe P04 Galvanized			1
16	Terminal	-			1
17	Terminal box cover	Aluminium (three phase version)			1
18	Splash ring Up to 11 kW	NBR	40x21.5x2	EBARA DRAWING	1
19	Bearing [10]	-			1
20	Bearing [10]	-			1
21	Adjusting ring	Steel C70			1
22	Tie rod	Fe 42 Galvanized	M5 M6 M8	EBARA DRAWING	4
24	Priming plug	Brass	G 3/8" L=8		1
25	Draing plug	Brass	G 3/8" L=8		1
26	O-ring	NBR/FPM/EPDM	158.11x5.34 183.52x5.34 227.96x5.34	OR 6625 OR 6720 OR 6895	1
32	Key Up to 11 kW	EN 1.4401 (AISI 316)	A 6x6x25	UNI 6604	1
34	Impeller nut Up to 11 kW	EN 1.4301 (AISI 304)	M16x1.5	UNI 7474	1
42	Foot	Aluminium / Galvanized steel		EBARA DRAWING	1
56	Box gasket	NBR			1
58	Cable gland	-			1
72	Casing ring [5]	EN 1.4301 (AISI 304)			1
75	Washer	Aluminum	22x17x1.5	EBARA DRAWING	1
76	Washer	Aluminum	22x17x1.5	EBARA DRAWING	1
92	Lip seal	-	25x40x7 30x47X7 40x55x7	DIN 3760 without spring	1
93	Lip seal	-	25x40x7 30x47X7 40x55x7	DIN 3760 without spring	1
101	Snap ring [6]	Carbon tool steels TC 80	Ø 40	UNI 7435	1
200	Screw	Gv. Steel 8.8 strenght class ISO 898-1	M 8x30 M 10x35	UNI 5739	8 10 12
235	Washer	Galvanized Steel	8.4x17 10.5x21	UNI 6592	8 10 12

- [1] Cast iron EN-GJL-200-EN 1561 for 3D 32-200/3  
Aluminum AL-EN-1706-AC-46000-D for all the others
- [2] EN 1.4301 (AISI 304) for 32, 40, 50 series  
EN 1.4401 (AISI 316) for 65 series
- [3] See **CONSTRUCTION 3**
- [4] See **CONSTRUCTION 3**, "O-ring" column
- [5] Only for: 32-200, 40-200, 50-160, 50-200/9.2, 50-200/11
- [6] Only for pumps with 9.2 and 11 kW motor

(3/3)

# Construction

Pump Name 3D 32-160/2.2

Customer	Date 2026-05-21	Company
Contact	Item no.	Issued by
Phone	Project	Phone
E-mail	Project ID	E-mail

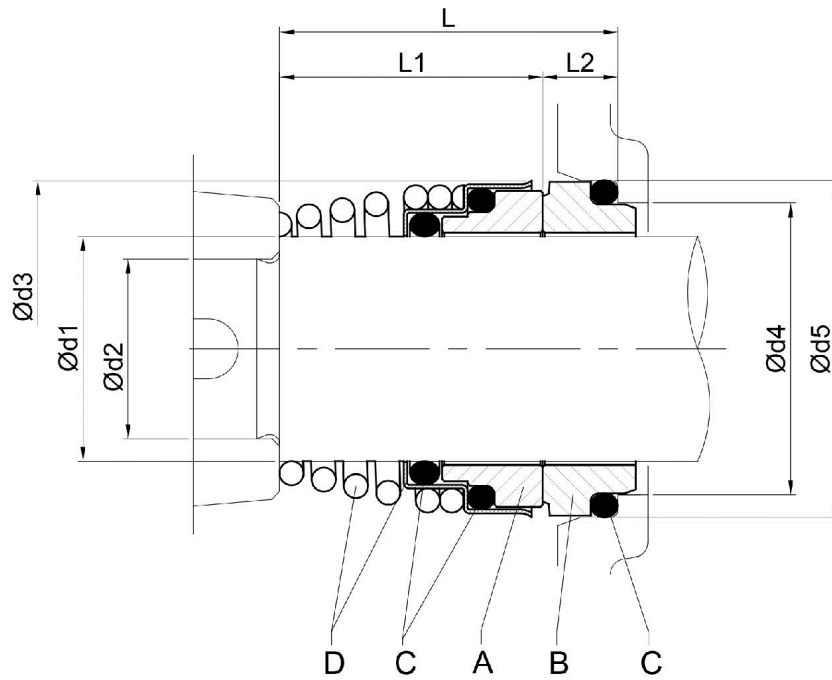

Pump type	Dimensions [ mm ]								Material Standard			
	d1	d2	d3	d4	d5	L	L1	L2	A Rotary seal ring	B Stationary seal ring	C O-ring	D Frame + Spring
32-125/160/200												
40-125/160/200												
50-125/160/200	22	19	38	31	37	37.5	27.5	10	Ceramic	Carbon	NBR	EN 1.4301 (AISI 304)
65-125												
65-160/7.5-9.2-11												